

ISS[®]
INSIDE SELF-STORAGE
WORLD EXPO

We Have Bright Ideas in
STORAGE.
2015





Building Code Updates and How They Affect Your Self-Storage Project

Presented by

Jamie Lindau, National Sales Manager

Ross Mori, Engineering Manager

Trachte Building Systems

Building Codes – IBC Codes

- Starting in 2000, building codes consolidated from at least five different codes into the IBC code
- Mostly a boom for self-storage because for many of the codes, the requirements were actually more relaxed than the current codes

Codes that went away:

- BOCA
 - Problem: Need 30' 1" driveways between buildings
 - Used on the East Coast to the Mississippi river
- UBC
 - Problem: Need 40' buffer for driveways
 - Used west of the Mississippi river
- SBC (Standard Building Code)
- New York and Wisconsin had their own codes



Building Requirement

In IBC code, typical self-storage buildings follow these requirements:

- Type of construction: Type IIB non-combustible (metal buildings)
- Type of construction: Type VB wood construction
- Use group: S-1 Moderate Hazard Storage
- Snow load: 30 pounds, for example
- Wind load: 90 miles per hour, for example
- Importance factor – determined by location of site compared to population or distance to ocean



PLAN 1

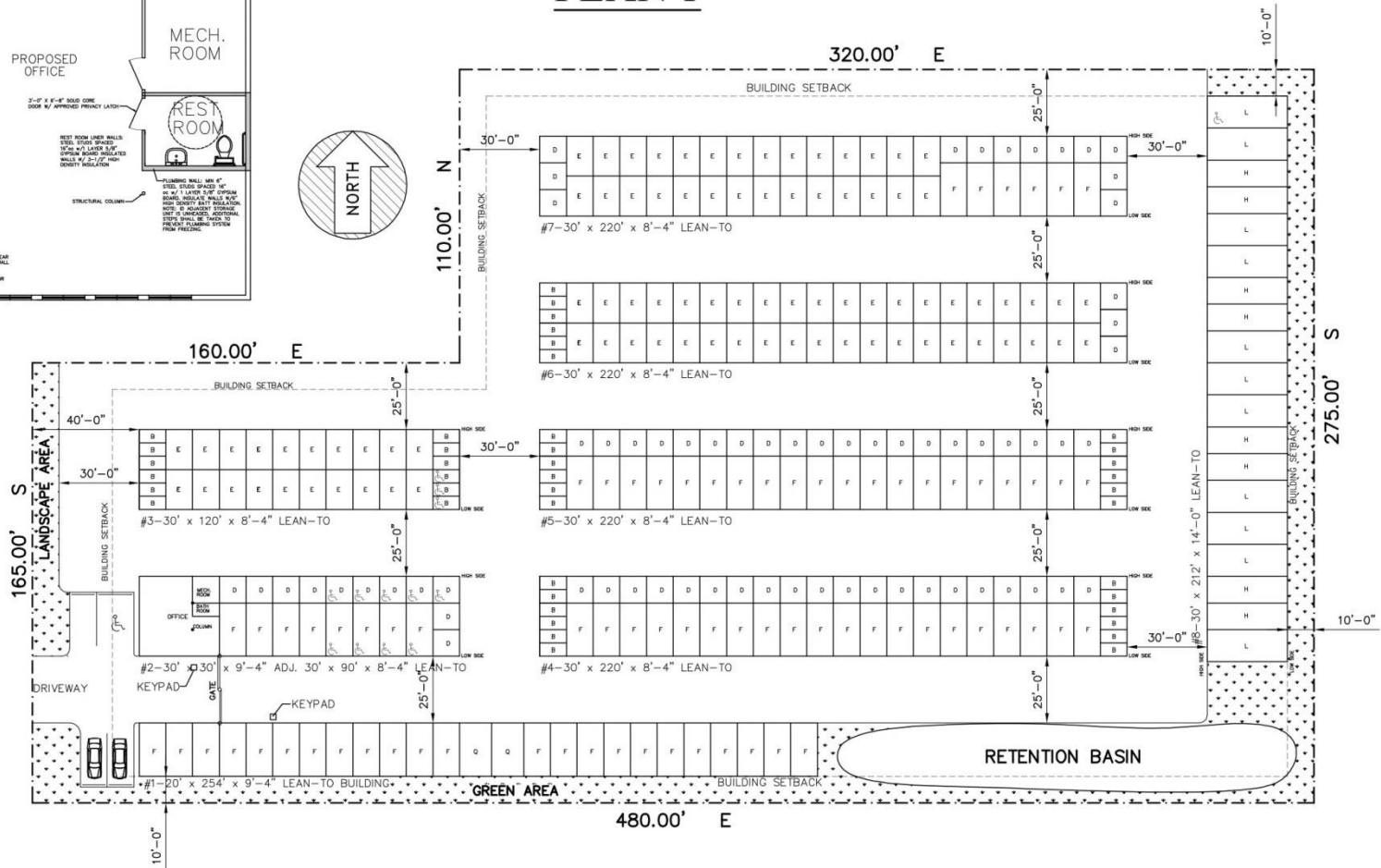
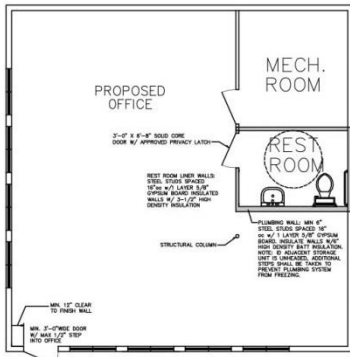

DESCRIPTION:

TYPICAL SITE LAYOUT
 TOTAL AREA = 114,400 SQ.FT. (2.63 ACRES)
 TOTAL BUILDING COVERAGE = 46,240 SQ.FT. (40%)
 TOTAL RENTABLE = 45,340 SQ.FT. (40%)
 TOTAL GREEN AREA (WITH RETENTION) = 13,409 SQ.FT. (12%)

SETBACK REQUIREMENTS

FRONT = 30'
 REAR/SIDE = 10'
 P-44807-1

UNIT MIX

LABEL	UNIT SIZE	# UNITS	%	SQ. FEET
B	5 x 10	42	13.9	2100
D	10 x 10	66	21.8	6600
E	10 x 15	96	31.7	14400
F	10 x 20	77	25.4	15400
H	10 x 30	8	2.6	2400
Q	12 x 20	2	0.7	480
L	12 x 30	11	3.6	3960
OFFI	30 x 300OFF	1	0.3	900
TOTAL		303	100	46240

TOTAL ADA UNITS = 13

♿ DENOTES HANDICAP/WHEELCHAIR ACCESSIBLE UNITS

PLAN 2

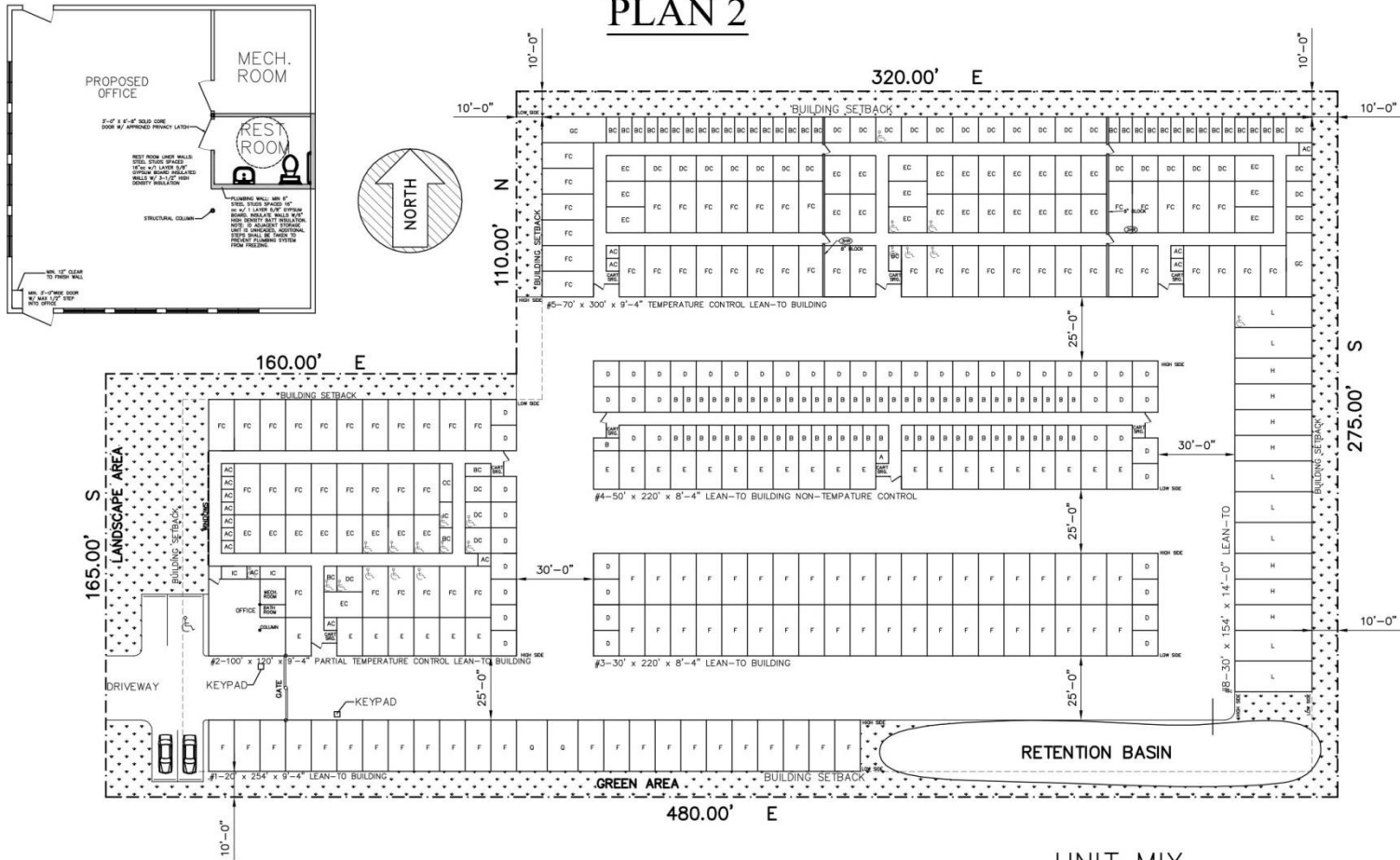

DESCRIPTION:

TYPICAL SITE LAYOUT

TOTAL AREA = 114,400 SQ.FT. (2.63 ACRES)
 TOTAL BUILDING COVERAGE = 60,300 SQ.FT. (53%)
 TOTAL RENTABLE = 55,725 SQ.FT. (49%)
 TOTAL GREEN AREA (WITH RETENTION) = 20,351 SQ.FT. (18%)

SETBACK REQUIREMENTS

FRONT = 30'
 REAR/SIDE = 10'
 P-44807-2

UNIT MIX

LABEL	UNIT SIZE	# UNITS	%	INSULATED	SQ. FEET
A	5 x 5	1	0.2	N	25
AC	5 x 5	15	3.6	Y	375
B	5 x 10	64	15.5	N	3200
BC	5 x 10	35	8.5	Y	1750
CC	5 x 15	1	0.2	Y	75
IC	10 x 5	3	0.7	Y	150
D	10 x 10	51	12.3	N	5100
DC	10 x 10	31	7.5	Y	3100
E	10 x 15	27	6.5	N	4050
EC	10 x 15	36	8.7	Y	5400
F	10 x 20	63	15.3	N	12600
FC	10 x 20	67	16.2	Y	13400
GC	10 x 25	2	0.5	Y	500
H	10 x 30	7	1.7	N	2100
Q	12 x 20	2	0.5	N	480
L	12 x 30	7	1.7	N	2520
OFFI	30 x 300FF	1	0.2	N	900
SQ.FT. NON-INSULATED					30,975
SQ.FT. INSULATED					24,750
TOTAL RENTABLE SQ.FT.					55,725
TOTAL GROSS SQ.FT.					60,300

TOTAL ADA UNITS = 20

TABLE 503—continued
ALLOWABLE BUILDING HEIGHTS AND AREAS^{a, b}

GROUP	HEIGHT (feet)	TYPE OF CONSTRUCTION								
		TYPE I		TYPE II		TYPE III		TYPE IV	TYPE V	
		A	B	A	B	A	B	HT	A	B
		UL	160	65	55	65	55	65	50	40
STORIES(S) AREA (A)										
M	S	UL	11	4	2	4	2	4	3	1
	A	UL	UL	21,500	12,500	18,500	12,500	20,500	14,000	9,000
R-1	S	UL	11	4	4	4	4	4	3	2
	A	UL	UL	24,000	16,000	24,000	16,000	20,500	12,000	7,000
R-2	S	UL	11	4	4	4	4	4	3	2
	A	UL	UL	24,000	16,000	24,000	16,000	20,500	12,000	7,000
R-3	S	UL	11	4	4	4	4	4	3	3
	A	UL	UL	UL	UL	UL	UL	UL	UL	UL
R-4	S	UL	11	4	4	4	4	4	3	2
	A	UL	UL	24,000	16,000	24,000	16,000	20,500	12,000	7,000
S-1	S	UL	11	4	2	3	2	4	3	1
	A	UL	48,000	26,000	17,500	26,000	17,500	25,500	14,000	9,000
S-2	S	UL	11	5	3	4	3	5	4	2
	A	UL	79,000	39,000	26,000	39,000	26,000	38,500	21,000	13,500
U	S	UL	5	4	2	3	2	4	2	1
	A	UL	35,500	19,000	8,500	14,000	8,500	18,000	9,000	5,500

For SI: 1 foot = 304.8 mm, 1 square foot = 0.0929 m².

A = building area per story, S = stories above grade plane, UL = Unlimited, NP = Not permitted.

a. See the following sections for general exceptions to Table 503:

1. Section 504.2, Allowable building height and story increase due to automatic sprinkler system installation.
2. Section 506.2, Allowable building area increase due to street frontage.
3. Section 506.3, Allowable building area increase due to automatic sprinkler system installation.
4. Section 507, Unlimited area buildings.

b. See Chapter 4 for specific exceptions to the allowable height and areas in Chapter 5.

[F] 903.2.9 Group S-1. An *automatic sprinkler system* shall be provided throughout all buildings containing a Group S-1 occupancy where one of the following conditions exists:

1. A Group S-1 *fire area* exceeds 12,000 square feet (1115 m²).
2. A Group S-1 *fire area* is located more than three stories above *grade plane*.
3. The combined area of all Group S-1 *fire areas* on all floors, including any mezzanines, exceeds 24,000 square feet (2230 m²).
4. A Group S-1 *fire area* used for the storage of commercial trucks or buses where the *fire area* exceeds 5,000 square feet (464 m²).



PLAN 2

3-Hour Firewall

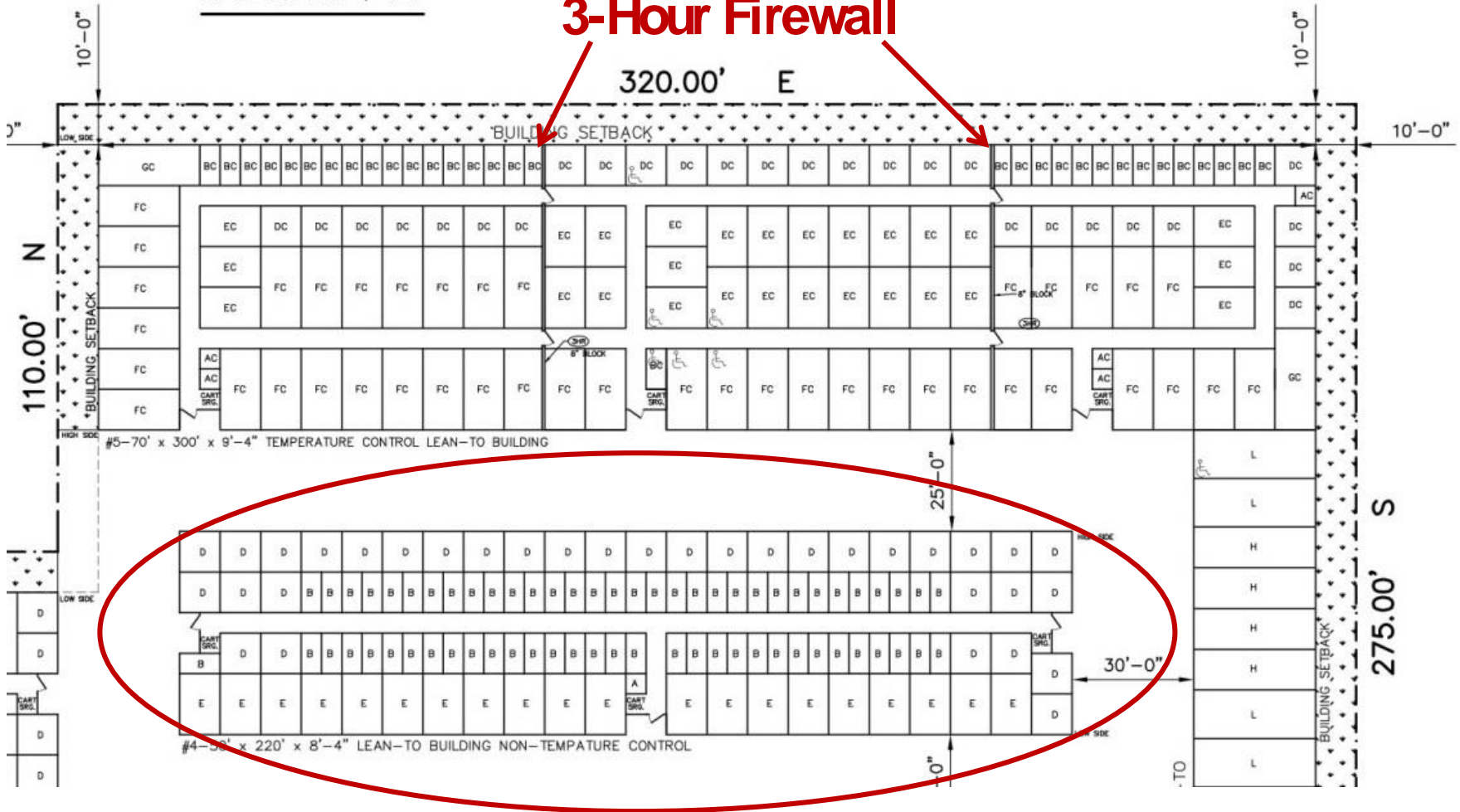

50' x 220' = 11,000' SF – No Firewall Needed

Firewall vs. Fire Assemblies

706.5 Horizontal continuity. *Fire walls* shall be continuous from *exterior wall* to *exterior wall* and shall extend at least 18 inches (457 mm) beyond the exterior surface of *exterior walls*.

Exceptions:

1. *Fire walls* shall be permitted to terminate at the interior surface of combustible exterior sheathing or siding provided the *exterior wall* has a *fire-resistance rating* of at least 1 hour for a horizontal distance of at least 4 feet (1220 mm) on both sides of the *fire wall*. Openings within such *exterior walls* shall be protected by opening protectives having a *fire protection rating* of not less than $\frac{3}{4}$ hour.
2. *Fire walls* shall be permitted to terminate at the interior surface of noncombustible exterior sheathing, exterior siding or other noncombustible exterior finishes provided the sheathing, siding, or other exterior noncombustible finish extends a horizontal distance of at least 4 feet (1220 mm) on both sides of the *fire wall*.
3. *Fire walls* shall be permitted to terminate at the interior surface of noncombustible exterior sheathing where the building on each side of the *fire wall* is protected by an *automatic sprinkler system* installed in accordance with Section 903.3.1.1 or 903.3.1.2.





**4' Blank Area to
Conform to Code**

ISS
INSIDE SELF-STORAGE
WORLD EXPO

We Have Bright Ideas in
STORAGE.
2015



InsideSelfStorageWorldExpo.com

TABLE 602
FIRE-RESISTANCE RATING REQUIREMENTS FOR EXTERIOR WALLS BASED ON FIRE SEPARATION DISTANCE^{a, e, h}

FIRE SEPARATION DISTANCE = X (feet)	TYPE OF CONSTRUCTION	OCCUPANCY GROUP H ^f	OCCUPANCY GROUP F-1, M, S-1 ^g	OCCUPANCY GROUP A, B, E, F-2, I, R, S-2 ^g , U ^b
X < 5 ^c	All	3	2	1
5 ≤ X < 10	IA	3	2	1
	Others	2	1	1
10 ≤ X < 30	IA, IB	2	1	1 ^d
	IIB, VB	1	0	0
	Others	1	1	1 ^d
X ≥ 30	All	0	0	0

For SI: 1 foot = 304.8 mm.

- a. Load-bearing exterior walls shall also comply with the fire-resistance rating requirements of Table 601.
- b. For special requirements for Group U occupancies, see Section 406.3.
- c. See Section 706.1.1 for party walls.
- d. Open parking garages complying with Section 406 shall not be required to have a fire-resistance rating.
- e. The fire-resistance rating of an exterior wall is determined based upon the fire separation distance of the exterior wall and the story in which the wall is located.
- f. For special requirements for Group H occupancies, see Section 415.5.
- g. For special requirements for Group S aircraft hangars, see Section 412.4.1.
- h. Where Table 705.8 permits nonbearing exterior walls with unlimited area of unprotected openings, the required fire-resistance rating for the exterior walls is 0 hours.



We Have Bright Ideas in
STORAGE.
2015



Building Codes-IBC Codes

- First big changes were the difference between the 2006 and 2009 IBC code
- In 2006 code, you could build a four-story building using typical self-storage design (type II non-combustible)
- In 2009 code, this was changed so you can only build a three-story
- Only exception is if the building is considered a basement, you can build a four-story structure



2006 IBC – 4-Story Building



ISS
INSIDE SELF-STORAGE
WORLD EXPO

We Have Bright Ideas in
STORAGE.
2015



InsideSelfStorageWorldExpo.com

2009 IBC – 3-Story With Basement



ISS
INSIDE SELF-STORAGE
WORLD EXPO

We Have Bright Ideas in
STORAGE.
2015



InsideSelfStorageWorldExpo.com

2009 IECC Code

- If your state follows this code, you'll have to increase your insulation requirement somewhat compared to 2006.
- Most buildings will need to include an R-5 thermal block when you install your standing-seam roof, and then you'll comply with the code.



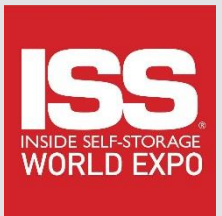

We Have Bright Ideas in
STORAGE.
2015



InsideSelfStorageWorldExpo.com



ISS
INSIDE SELF-STORAGE
WORLD EXPO

We Have Bright Ideas in
STORAGE.
2015



InsideSelfStorageWorldExpo.com



ISS
INSIDE SELF-STORAGE
WORLD EXPO

We Have Bright Ideas in
STORAGE.
2015



InsideSelfStorageWorldExpo.com



ISS
INSIDE SELF-STORAGE
WORLD EXPO

We Have Bright Ideas in
STORAGE.
2015



InsideSelfStorageWorldExpo.com

2012 IBC Code and 2012 IECC Code

Major changes will occur when these two codes are adopted in the state in which you live.



We Have Bright Ideas in
STORAGE.
2015



InsideSelfStorageWorldExpo.com

[F] **903.2.9 Group S-1.** An *automatic sprinkler system* shall be provided throughout all buildings containing a Group S-1 occupancy where one of the following conditions exists:

1. A Group S-1 *fire area* exceeds 12,000 square feet (1115 m²).
2. A Group S-1 *fire area* is located more than three stories above *grade plane*.
3. The combined area of all Group S-1 *fire areas* on all floors, including any mezzanines, exceeds 24,000 square feet (2230 m²).
4. A Group S-1 *fire area* used for the storage of commercial trucks or buses where the *fire area* exceeds 5,000 square feet (464 m²).
5. A Group S-1 occupancy used for the storage of upholstered furniture or mattresses exceeds 2,500 square feet (232 m²).



2012 IBC Code

Section 903.2.9 – Means that if your building is over 2,500 square feet, you'll need to sprinkler the buildings or add fire walls.

- The fire walls will be 3-hour drywall or concrete block.

The other possible option is to state in your lease agreement that you won't store furniture or bedding, and then see if you'll get approval.



PLAN 1

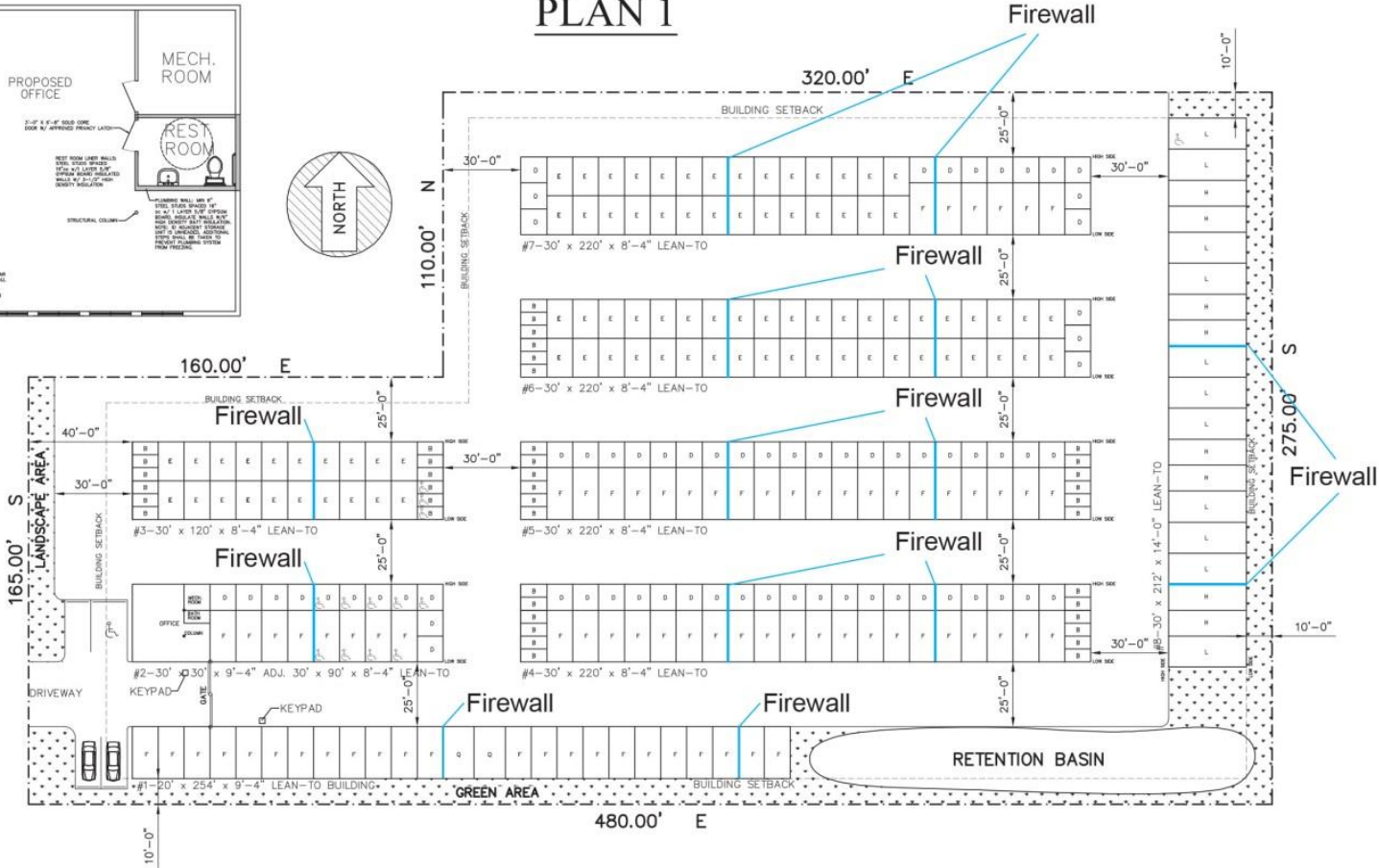
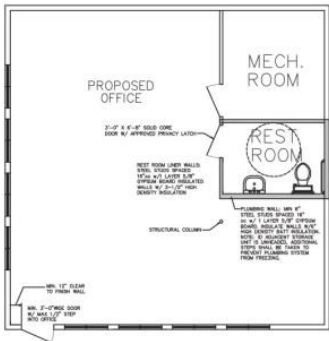

DESCRIPTION:

TYPICAL SITE LAYOUT
 TOTAL AREA = 114,400 SQ.FT. (2.63 ACRES)
 TOTAL BUILDING COVERAGE = 46,240 SQ.FT. (40%)
 TOTAL RENTABLE = 45,340 SQ.FT. (40%)
 TOTAL GREEN AREA (WITH RETENTION) = 13,409 SQ.FT. (12%)
 SETBACK REQUIREMENTS
 FRONT = 30'
 REAR/SIDE = 10'
 P-44807-1

Blue lines denote 3 hour firewall

UNIT MIX

LABEL	UNIT SIZE	# UNITS	%	SQ. FEET
B	5 x 10	42	13.9	2100
D	10 x 10	66	21.8	6600
E	10 x 15	96	31.7	14400
F	10 x 20	77	25.4	15400
H	10 x 30	8	2.6	2400
Q	12 x 20	2	0.7	480
L	12 x 30	11	3.6	3960
OFF1	30 x 300FF	1	0.3	900
TOTAL		303	100	46240

TOTAL ADA UNITS = 13

DENOTES HANDICAP/WHEELCHAIR ACCESSIBLE UNITS

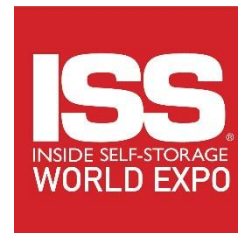

Need Wider Unit or Smaller Door



ISS
INSIDE SELF-STORAGE
WORLD EXPO

We Have Bright Ideas in
STORAGE.
2015



InsideSelfStorageWorldExpo.com

PLAN 2

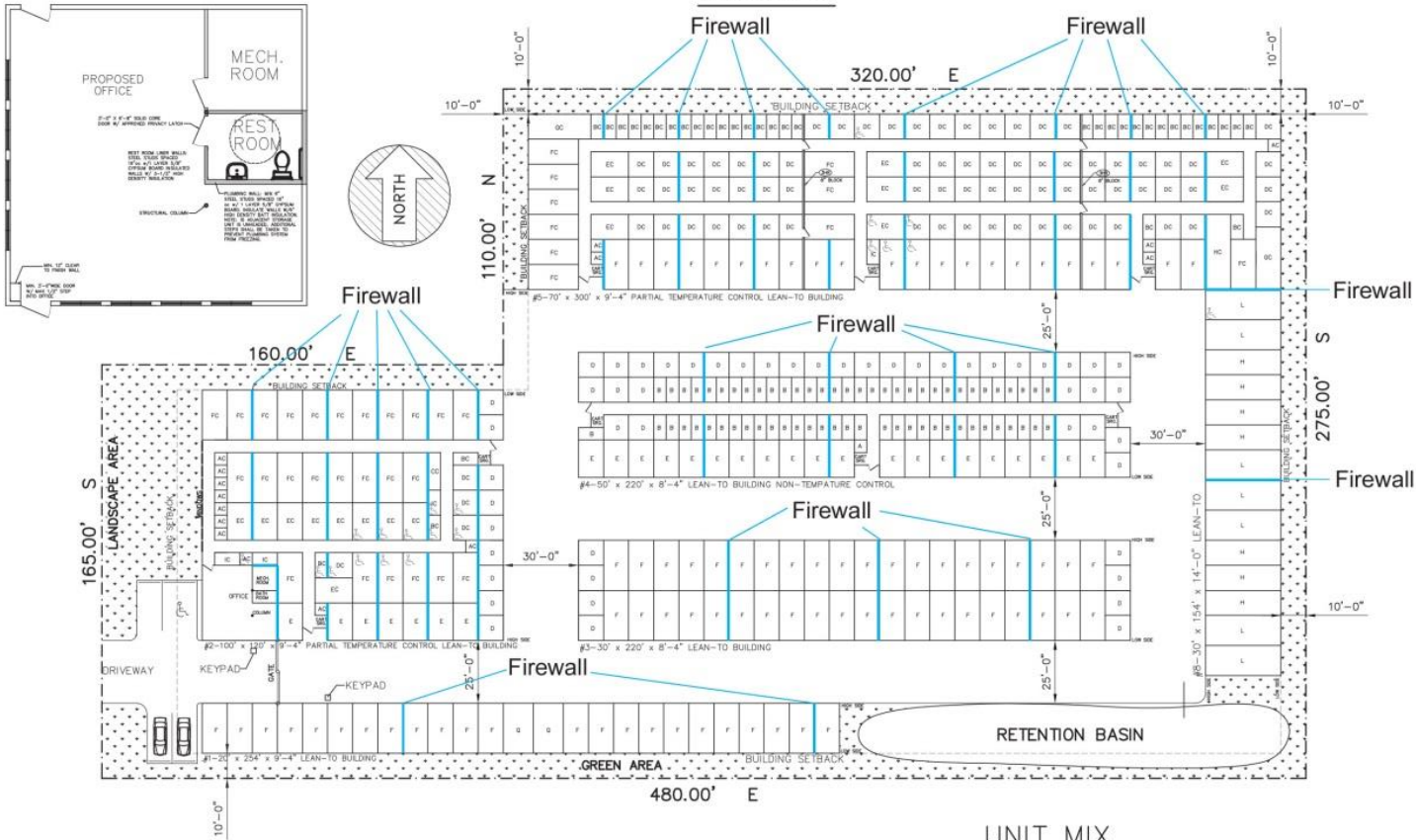

DESCRIPTION:

TYPICAL SITE LAYOUT
 TOTAL AREA = 114,400 SQ.FT. (2.63 ACRES)
 TOTAL BUILDING COVERAGE = 60,300 SQ.FT. (53%)
 TOTAL RENTABLE = 55,675 SQ.FT. (49%)
 TOTAL GREEN AREA (WITH RETENTION) = 20,351 SQ.FT. (18%)
 SETBACK REQUIREMENTS
 FRONT = 30'
 REAR/SIDE=10'
 P-44807-2

— Blue lines denote 3 hour firewall

UNIT MIX

LABEL	UNIT SIZE	# UNITS	%	SQ. FEET	INSULATED
A	5 x 5	1	0.2	25	N
AC	5 x 5	15	3.5	375	Y
B	5 x 10	64	14.8	3200	N
BC	5 x 10	36	8.4	1800	Y
CC	5 x 15	1	0.2	75	Y
IC	10 x 5	4	0.9	200	Y
D	10 x 10	51	11.8	5100	N
DC	10 x 10	75	17.4	7500	Y
E	10 x 15	27	6.3	4050	N
EC	10 x 15	17	3.9	2550	Y
F	10 x 20	85	19.7	17000	N
FC	10 x 20	35	8.1	7000	Y
GC	10 x 25	2	0.5	500	Y
H	10 x 30	7	1.6	2100	N
HC	10 x 30	1	0.2	300	Y
Q	12 x 20	2	0.5	480	N
L	12 x 30	7	1.6	2520	N
OFF1	30 x 30OFF	1	0.2	900	N
TOTAL UNITS					413
SQ.FT. NON-INSULATED					35,375
SQ.FT. INSULATED					20,300
TOTAL RENTABLE SQ.FT.					55,675
TOTAL GROSS SQ.FT.					60,300

TOTAL ADA UNITS = 20

♿ DENOTES HANDICAP/WHEELCHAIR ACCESSIBLE UNITS

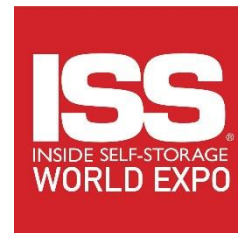

2012 IBC Code

Plan 1

- Not a drastic problem
- Just means you'll need additional firewalls

Plan 2

- Not feasible to add all the firewalls, plus building 2 will have to change its unit mix to conform to section 706.5
- Answer is to sprinkler the two large buildings
- Additional cost should be planned up front so you know your project will still pencil out with these additional expenses



2012 IECC Code

- Latest federal guidelines for the heat and energy code
- Country has increased its requirements on the amount of insulation needed in a building
- Very important to determine if your next project will be following these guidelines

Two types of methods to figure out how much insulation:

- **Prescriptive** – Exact listing of insulation requirement
- **Tested systems** – Purchase from a company that has a proven tested product



Select a state 

Commercial: Current

Residential: Current

Current Commercial Building Energy Code Adoption Status

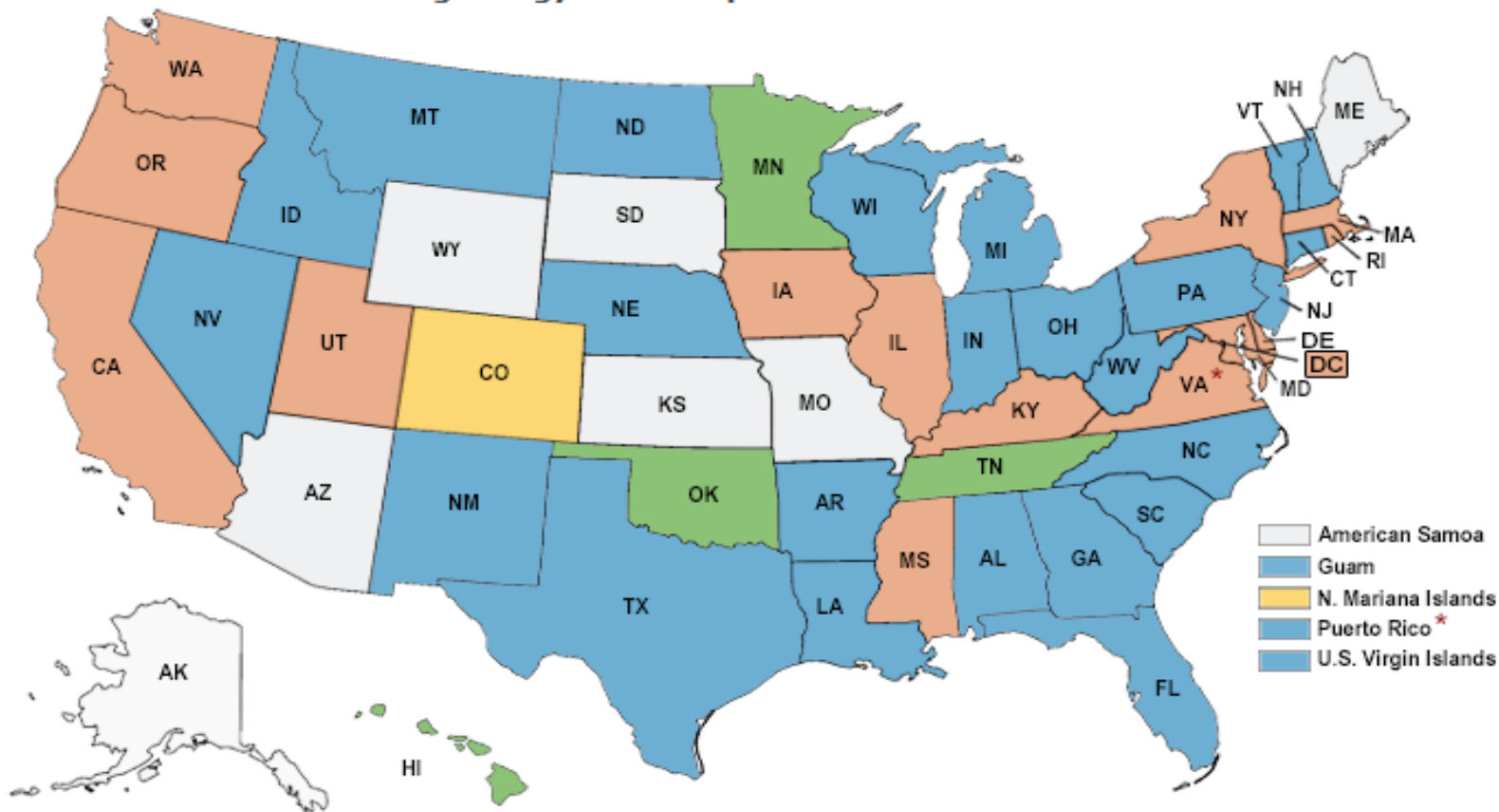

* Adopted new Code to be effective at a later date

Climate Zones

2012 IECC - Chapter 3

U.S. DEPARTMENT OF
ENERGY

Energy Efficiency &
Renewable Energy

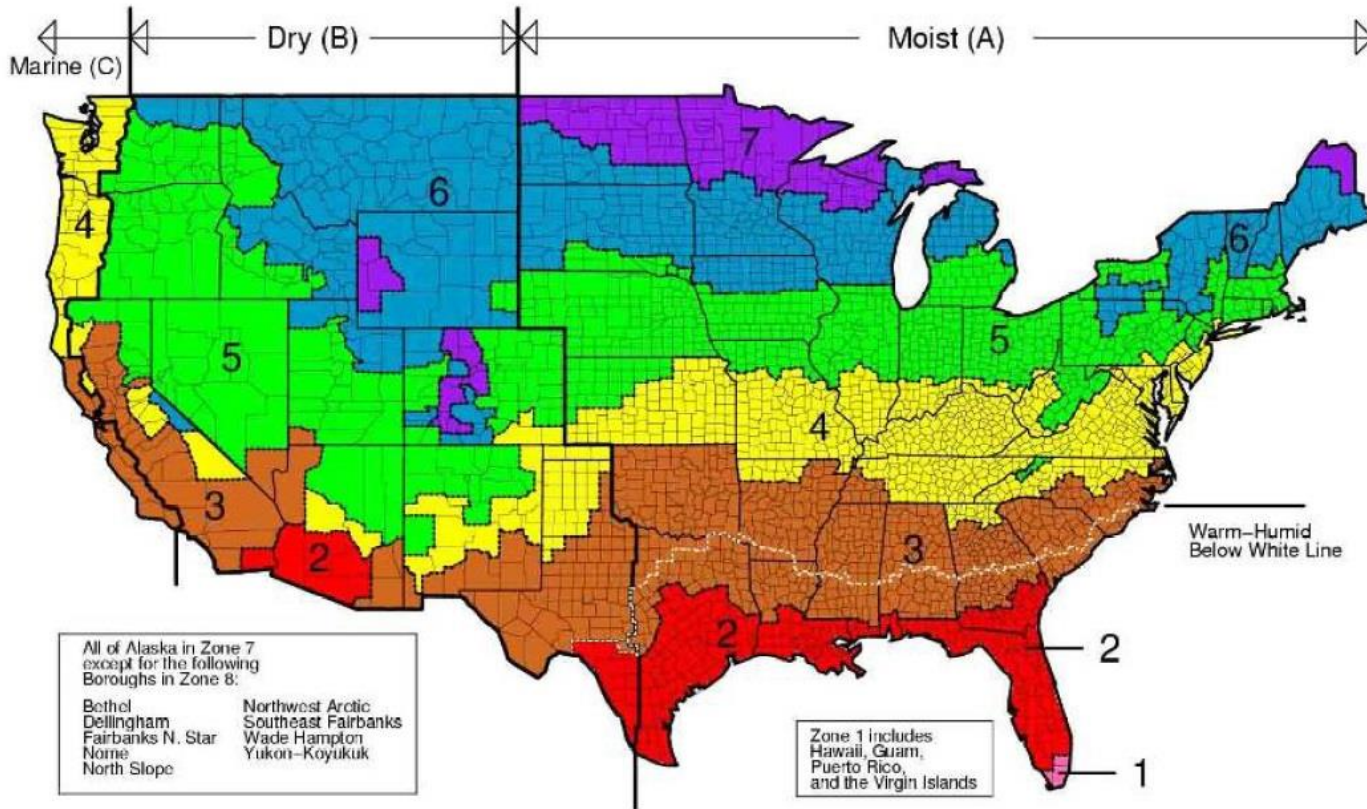

Determining Your Climate Zone is the First Step in the Process

11

ISS
INSIDE SELF-STORAGE
WORLD EXPO

We Have Bright Ideas in
STORAGE.
2015



InsideSelfStorageWorldExpo.com

Chapter 5 Prescriptive Approach Compliance

TABLE C402.2
OPAQUE THERMAL ENVELOPE REQUIREMENTS*

CLIMATE ZONE	1		2		3		4 EXCEPT MARINE		5 AND MARINE 4		6		7		8	
	All Other	Group R	All Other	Group R	All Other	Group R	All Other	Group R	All Other	Group R	All Other	Group R	All Other	Group R	All Other	Group R
ROOFS																
Insulation entirely above deck	R-20ci	R-20ci	R-20ci	R-20ci	R-20ci	R-20ci	R-25ci	R-25ci	R-25ci	R-25ci	R-30ci	R-30ci	R-35ci	R-35ci	R-35ci	R-35ci
Metal buildings (with R-5 thermal blocks) ^{a,b}	R-19+ R-11LS	R-19+ R-11LS	R-19+ R-11LS	R-19+ R-11LS	R-19+ R-11LS	R-19+ R-11LS	R-19+ R-11LS	R-19+ R-11LS	R-19+ R-11LS	R-19+ R-11LS	R-25+ R-11LS	R-25+ R-11LS	R-30+ R-11LS	R-30+ R-11LS	R-30+ R-11LS	R-30+ R-11LS
Attic and other	R-38	R-38	R-38	R-38	R-38	R-38	R-38	R-38	R-38	R-38	R-49	R-49	R-49	R-49	R-49	R-49

Climate Zone	1	2	3	4 Except Marine	5 And Marine 4	6	7	8								
Insulation entirely above deck	R-20ci	R-20ci	R-20ci	R-20ci	R-20ci	R-20ci	R-25ci	R-25ci	R-25ci	R-25ci	R-30ci	R-30ci	R-35ci	R-35ci	R-35ci	R-35ci
Metal buildings (with R-5 thermal blocks)	R-19+ R-11 LS	R-19+ R-11 LS	R-19+ R-11 LS	R-19+ R-11 LS	R-19+ R-11 LS	R-19+ R-11 LS	R-19+ R-11 LS	R-19+ R-11 LS	R-19+ R-11 LS	R-19+ R-11 LS	R-25+ R-11 LS	R-25+ R-11 LS	R-30+ R-11 LS	R-30+ R-11 LS	R-30+ R-11 LS	R-30+ R-11 LS
Attic and other	R-38	R-38	R-38	R-38	R-38	R-38	R-38	R-38	R-38	R-38	R-49	R-49	R-49	R-49	R-49	R-49
Heated slabs ^c	R-5 for 12" below	R-5 for 12" below	R-5 for 12" below	R-5 for 12" below	R-5 for 24" below	R-5 for 24" below	R-5 for 24" below	R-5 for 24" below	R-5 for 24" below	R-5 for 24" below	R-5 for 24" below	R-5 for 24" below	R-5 for 24" below	R-5 for 24" below	R-5 for 24" below	R-5 for 24" below
Opaque Doors																
Swinging	U-0.64	U-0.64	U-0.64	U-0.64	U-0.64	U-0.64	U-0.64	U-0.64	U-0.64	U-0.64	U-0.64	U-0.64	U-0.64	U-0.64	U-0.64	U-0.64
Roll-up or sliding	R-4.35	R-4.35	R-4.35	R-4.35	R-4.35	R-4.35	R-4.35	R-4.35	R-4.35	R-4.35	R-4.35	R-4.35	R-4.35	R-4.35	R-4.35	R-4.35

For SL, 1 inch = 25.4 mm. ci = Continuous insulation. NR = No requirement.

LS = Liner System—A continuous membrane installed below the partition and uninterrupted by framing members. Uncompressed, unfaced insulation rests on top of the membrane between the purlins.

a. Assembly descriptions can be found in ANSI/AIAA/IESNA Appendix A.

b. Where using R-value compliance method, a thermal spacer block shall be provided, otherwise use the f-factor compliance method in Table C402.1.2.

c. R-5.7ci is allowed to be substituted with concrete block walls complying with ASTM C 90, being routed or partially grouted at 32 inches or less on center vertically and 48 inches or less on center horizontally, with ungrouted cores filled with materials having a maximum thermal conductivity of 0.44 Btu-in/h²-F.

d. Where heated slabs are below grade, below-grade walls shall comply with the exterior insulation requirements for heated slabs.

e. Steel floor joist systems shall be insulated to R-38.

2012 IECC Code Guidelines

LS = liner system

- A continuous membrane installed below the purlins and uninterrupted by framing members
- Uncompressed insulation rests on top of the membrane between the purlins

CI = continuous insulation

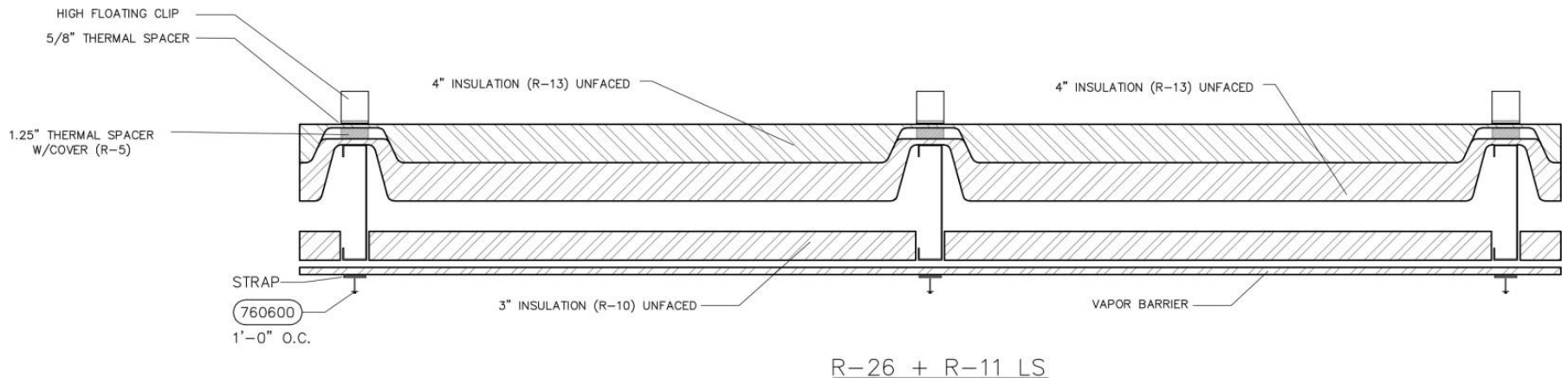

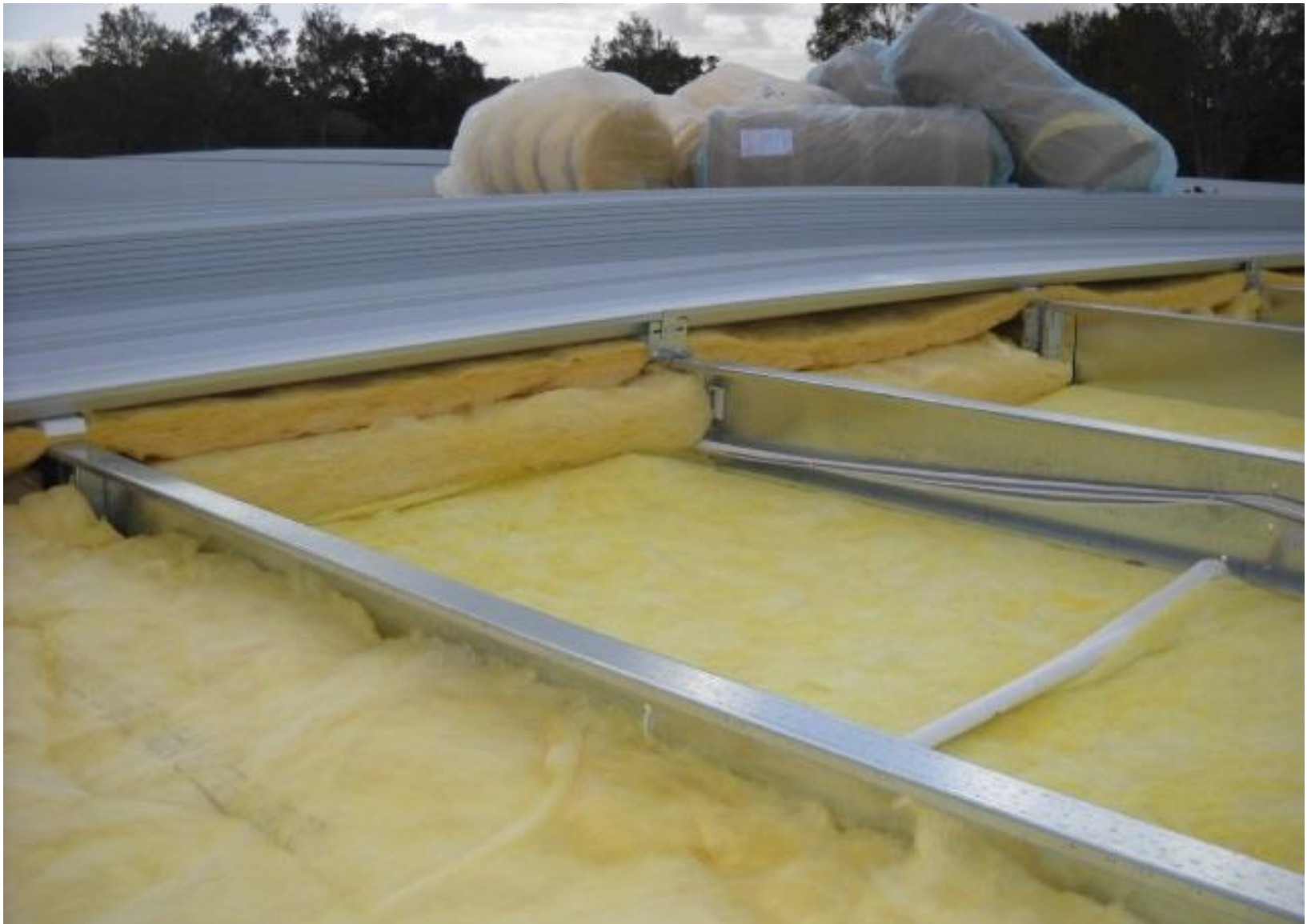

ISS
INSIDE SELF-STORAGE
WORLD EXPO

We Have Bright Ideas in
STORAGE.
2015



InsideSelfStorageWorldExpo.com

2012 IECC Code

- Short-term problem is it's much more expensive to build, but in the long run, your expenses will be lower due to a more efficient building.
- In the long run, the additional insulation will pay for itself.
- Remember if you lower your expenses, this will increase your NOI, which will make your project more valuable.



Thermal Liner System

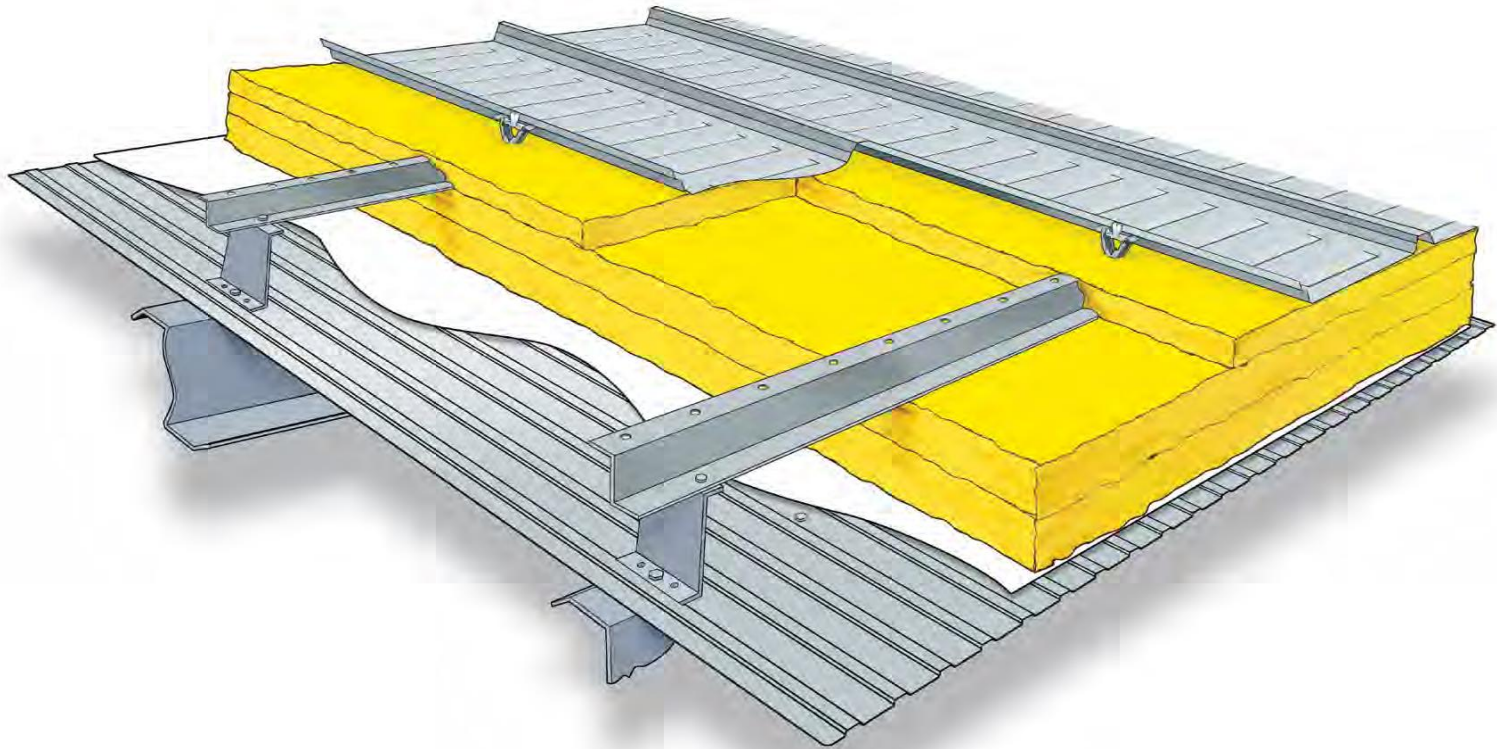

ISS
INSIDE SELF-STORAGE
WORLD EXPO

We Have Bright Ideas in
STORAGE.
2015



InsideSelfStorageWorldExpo.com

2012 IECC Code, Partial Climate Control

PLAN 2 Partial Temperature Control

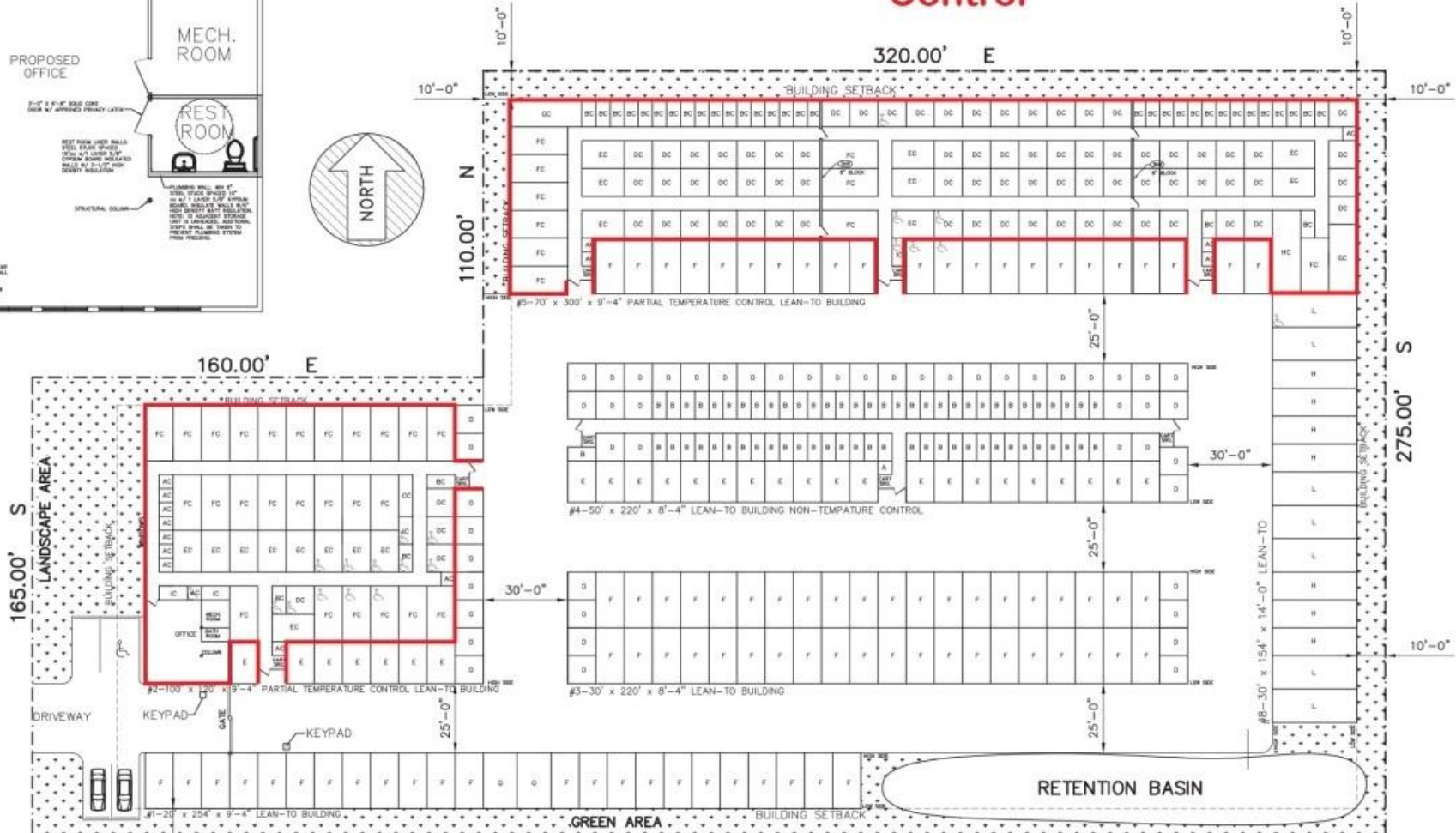
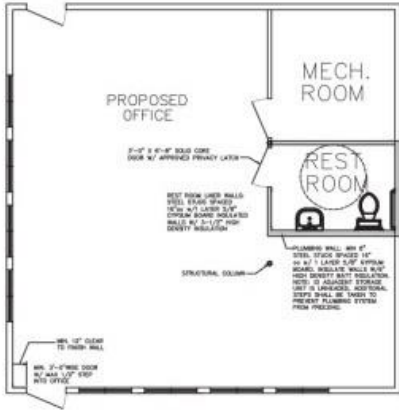

2012 IECC Code, Full Climate Control

PLAN 2 Fully Temperature Control

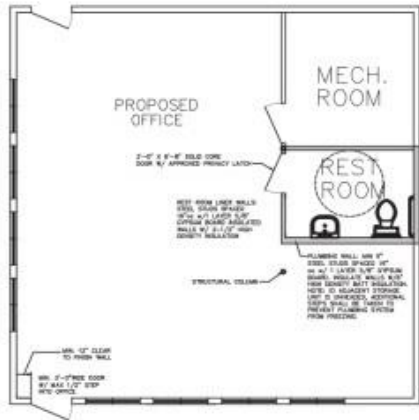



We Have Bright Ideas in
STORAGE.
2015



InsideSelfStorageWorldExpo.com

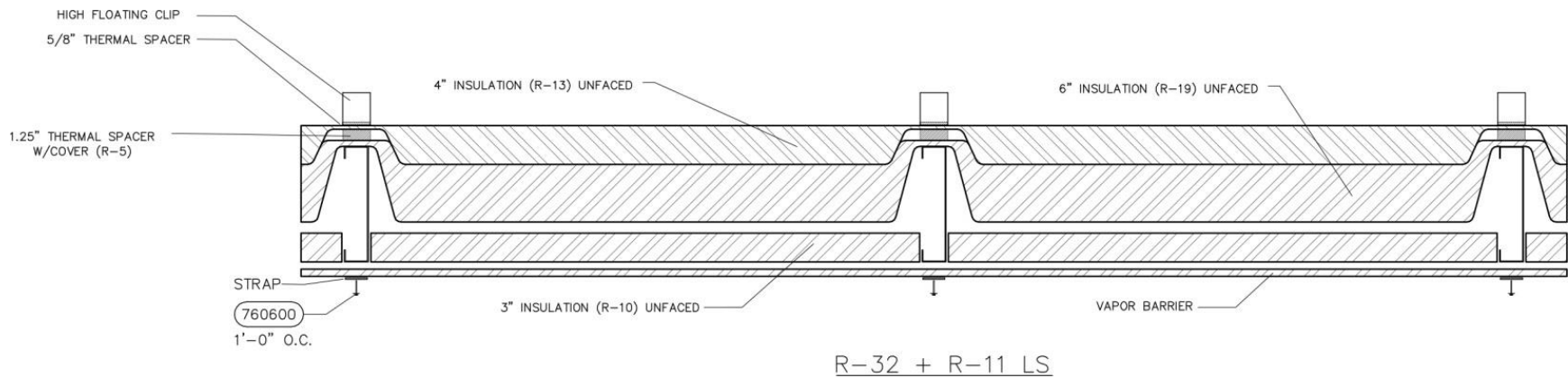
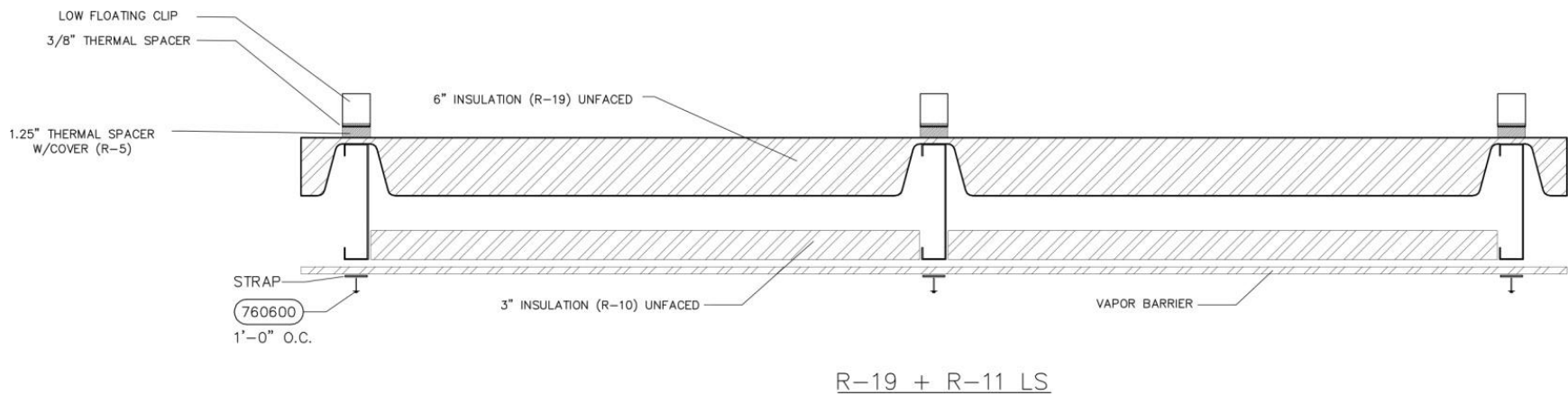
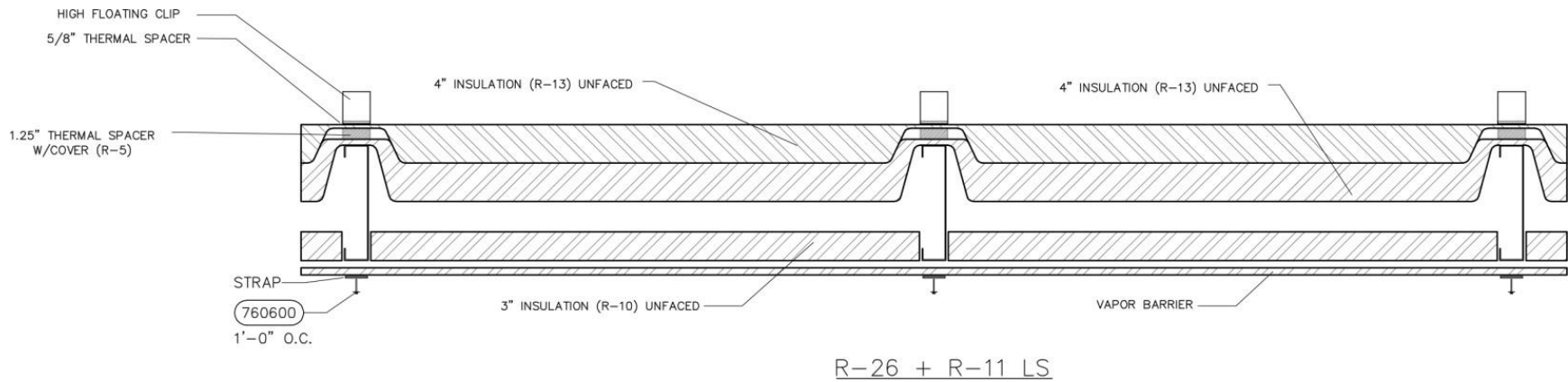



ISS
INSIDE SELF-STORAGE
WORLD EXPO

We Have Bright Ideas in
STORAGE.
2015



InsideSelfStorageWorldExpo.com



ISS
INSIDE SELF-STORAGE
WORLD EXPO

We Have Bright Ideas in
STORAGE.
2015



InsideSelfStorageWorldExpo.com

Chapter 5 Prescriptive Approach Compliance

TABLE C402.2
OPAQUE THERMAL ENVELOPE REQUIREMENTS*

CLIMATE ZONE	1		2		3		4 EXCEPT MARINE		5 AND MARINE 4		6		7		8	
	All Other	Group R	All Other	Group R	All Other	Group R	All Other	Group R	All Other	Group R	All Other	Group R	All Other	Group R	All Other	Group R
Roofs																
Insulation entirely above deck	R-20ci	R-20d	R-20ci	R-20ci	R-20d	R-20ci	R-25ci	R-25d	R-25ci	R-25ci	R-30d	R-30ci	R-35ci	R-35d	R-35ci	R-35ci
Metal buildings (with R-5 thermal break)**	R-19+ R-11LS	R-19+ R-11LS	R-19+ R-11LS	R-19+ R-11LS	R-19+ R-11LS	R-19+ R-11LS	R-19+ R-11LS	R-19+ R-11LS	R-19+ R-11LS	R-19+ R-11LS	R-25+ R-11LS	R-25+ R-11LS	R-30+ R-11LS	R-30+ R-11LS	R-30+ R-11LS	R-30+ R-11LS
Any and Other	R-38	R-38	R-38	R-38	R-38	R-38	R-38	R-38	R-38	R-38	R-38	R-38	R-38	R-38	R-38	R-38

WALLS, ABOVE GRADE

Climate Zone	1		2		3		4 Except Marine		5 And Marine 4		6		7		8	
Mass	R-5.7ci	R-5.7ci	R-5.7ci	R-7.6ci	R-7.6ci	R-9.5ci	R-9.5ci	R-11.4ci	R-11.4ci	R-13.3ci	R-13.3ci	R-15.2ci	R-15.2ci	R-15.2ci	R-25ci	R-25ci
Metal building	R-13+ 6.5ci	R-13+ 6.5ci	R-13+ 6.5ci	R-13+R- 13 ci	R-13+R- 13 ci	R-13+R- 13 ci	R-13+R- 13 ci	R-13+R- 13 ci	R-13+R- 13 ci	R-13+R- 13 ci	R-13+R- 13 ci	R-13+R- 13 ci	R-13+R- 13 ci	R-13+R- 19.5 ci	R-13+R- 13 ci	R-13+R- 19.5 ci
Metal Framed	R-13= R-5 ci	R-13= R-5 ci	R-13= R-5 ci	R-13+ 7.5ci	R-13+ 7.5ci	R-13+ 7.5ci	R-13+ 7.5ci	R-13+ 7.5ci	R-13+ 7.5ci	R-13+ 7.5ci	R-13+ 7.5ci	R-13+ 7.5ci	R-13+ 7.5ci	R-13+ 15.6ci	R-13+ 7.5ci	R-13+ 17.5ci
Wood Framed & Other	R-13+R- 3.8ci or R- 20	R-13+R- 3.8ci or R- 20	R-13+R- 3.8ci or R- 20	R-13+R- 3.8ci or R- 20	R-13+R- 3.8ci or R- 20	R-13+R- 3.8ci or R- 20	R-13+R- 3.8ci or R- 20	R-13+R- 3.8ci or R- 20	R-13+R- 3.8ci or R- 20	R-13+R- 7.5ci or R- 20+R- 3.8 ci	R-13+R- 7.5ci or R- 20+R- 3.8 ci	R-13+R- 7.5ci or R- 20+R- 3.8 ci	R-13+R- 7.5ci or R- 20+R- 3.8 ci	R-13+R- 7.5ci or R- 20+R- 3.8 ci	R-13+R- 15.6ci or R- 20+R- 10ci	R-13+R- 15.6ci or R- 20+R- 10 ci

- a. Assembly descriptions can be found in ANSI/ASHRAE/IESNA Appendix A.
- b. Where using R-value compliance method, thermal break block shall be provided, otherwise use the U-factor compliance method in Table C402.1.2.
- c. R-5.7ci is allowed to be substituted with concrete block walls complying with ASTM C 90, using grooves or partially grooved at 32 inches or less on center vertically and 48 inches or less on center horizontally, with unground cores filled with materials having a maximum thermal conductivity of 0.44 Btu-inh⁻²-F⁻¹.
- d. Where heated slabs are below grade, below grade walls shall comply with the exterior insulation requirements for heated slabs.
- e. Steel floor joist systems shall be insulated to R-38.



ISS
INSIDE SELF-STORAGE
WORLD EXPO

We Have Bright Ideas in
STORAGE.
2015



InsideSelfStorageWorldExpo.com

ADA Code Compliance – Units

1107.6 Self-service storage facilities.

Self-service storage facilities shall provide accessible individual self-storage spaces in accordance with Table 1107.6.

TABLE 1107.6

ACCESSIBLE SELF-SERVICE STORAGE FACILITIES

Total Spaces in Facility	Minimum # of Required Accessible Spaces
1 to 200	5%, but not less than 1
More than 200	10, plus 2% of total number of units over 200



*SLOPE CONCRETE TO INSIDE OF NOTCH

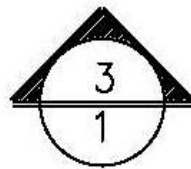
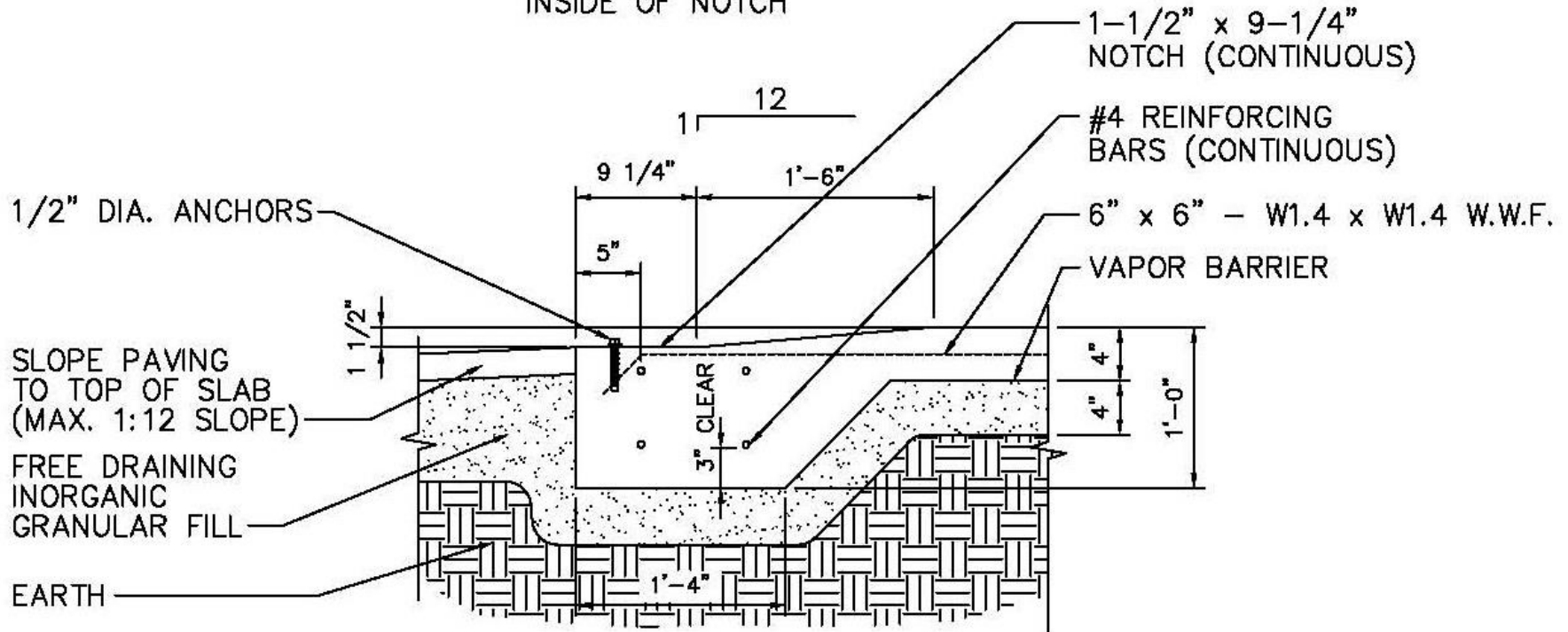

SLAB @ HANDICAP SLOPE DETAIL

1"=1'-0"





ISS
INSIDE SELF-STORAGE
WORLD EXPO

We Have Bright Ideas in
STORAGE.
2015



InsideSelfStorageWorldExpo.com



ISS
INSIDE SELF-STORAGE
WORLD EXPO

We Have Bright Ideas in
STORAGE.
2015



InsideSelfStorageWorldExpo.com





ISS
INSIDE SELF-STORAGE
WORLD EXPO

We Have Bright Ideas in
STORAGE.
2015



InsideSelfStorageWorldExpo.com



ISS
INSIDE SELF-STORAGE
WORLD EXPO

We Have Bright Ideas in
STORAGE.
2015



InsideSelfStorageWorldExpo.com

ADA Code Compliance – Corridors





ADA Code Compliance – Firewalls



Contact the Presenters



Jamie Lindau

National Sales Manager
Trachte Building Systems
800.356.5824

jlindau@trachte.com
www.trachte.com



Ross Mori

Engineering Manager
Trachte Building Systems
800.356.5824

rmori@trachte.com
www.trachte.com



ISS[®]
INSIDE SELF-STORAGE
WORLD EXPO

Thank You!

ISS
INSIDE SELF-STORAGE
WORLD EXPO

We Have Bright Ideas in
STORAGE.
2015

